

LS100Plus 100 kN Universal Materials Testing Machine

The LS100Plus advanced materials testing machine incorporates an extensive range of features making it ideal for performing complex as well as routine testing applications up to 100 kN (22481 lbf). The standard LS100Plus features a twin column design with a maximum crosshead travel of 824 mm (32.4 in). Extended machine column options (LS100Plus-E models) for testing high elongation materials are also available.

This bench mounted machine is microprocessor controlled and incorporates world proven 32 bit technology for highly accurate load measurement and rapid data acquisition. The LS100Plus features an integral user interface consisting of a side mounted control console with large, positive action membrane keys, allowing complex tests to be performed at the touch of a button. A back lit 4 line LCD display shows the test and set-up information in a wide choice of user selectable languages and units.

The stand alone system is capable of storing up to 600 test results from a choice of ten programmable

test set-ups. Test parameters are entered using the keypad in a sequential menu driven format.

For additional flexibility, the LS100Plus can also be connected to a personal computer with optional Lloyd Instruments NEXYGENPlus material test and control software. NEXYGENPlus software provides almost unlimited testing and results processing capability in a familiar Windows® environment.

The high stiffness frame incorporates a crosshead guidance system to prevent side loading of the sample under test. The crosshead is driven by twin lead screws and a high precision servo motor and DC servo system to achieve a wide range of speeds.

A series of highly accurate, interchangeable load cells is available for tension, compression and cycling through zero force measurements. Our extensive range of grips and fixtures support virtually any type of test. The system is ideal for use in production, quality control, educational and research environments.

Features

- Simple to set up, operate and maintain
- High accuracy load measurement
- Constant load holding
- Data sampling rate 8 kHz
- Load rate control
- Saves up to 600 test results
- 10 programmable test set-ups
- Pre-loading of samples and cycling to load or extension limits
- Multi-stage testing with NEXYGENPlus software
- Extension resolution <0.03 microns
- Multi-lingual display options
- Multi-unit display options
- Flash upgradeable
- Wide selection of load cells, grips, jigs, extensometers, temperature chambers and other accessories

Specifications

Force Capacity:	
LS100Plus (Standard)	100 kN (22481 lbf)
LS100Plus-E (Extended)	100 kN (22481 lbf)
Crosshead Speed Range:	0.001 to 254 mm/min from 0 to 50 kN (0.00004 to 10 in/min from 0 to 11241 lbf) 0.001 to 101.6 mm/min from 50 to 100 kN (0.00004 to 4 in/min from 11241 to 22481 lbf)
Speed Accuracy:	< 0.2% at steady state
Maximum Crosshead Travel:	
LS100Plus	842 mm (32.4 in)
LS100Plus-E	1012 mm (39.8 in)
Width Between Columns:	404 mm (16 in)
Minimum Load Resolution:	0.0001 N (load cell specific)
Load Cell Accuracy:	<0.5%
Extension Resolution:	<0.03 microns
Data Sampling Rate:	8 kHz
Display:	40 character x 4 line backlit LCD
Extensometer Inputs:	Digital and Analogue
Load Measuring System:	EN ISO 7500:2004 Class 0.5 ASTM E4
Software:	NEXYGENPlus Data Analysis Software (optional)
Supply Voltage:	230Vac ±10%, 50-60 Hz, Fuse T5AH250V 115Vac ±10%, 50-60 Hz, Fuse T10AH250V
Weight:	
LS100Plus	200 kg (441 lb)
LS100Plus-E	204 kg (450 lb)
Operating Temperature:	5° to 35° C (41° to 95°F)



Accessories

Item	Part No	Item	Part No
Load Cells:		Grips & Fixtures:	
5 N (1.12 lbf)	01/2946	A wide range of grips and fixtures are available. For further information see our grip specification sheets.	
10 N (2.25 lbf)	01/2360		
20 N (4.5 lbf)	01/2950		
50 N (11.25 lbf)	01/2361	Extensometers:	
100 N (22.5 lbf)	01/2480	We supply contacting and non-contacting extensometers. For further information see our extensometer specification sheets.	
250 N (56.25 lbf)	01/3048		
500 N (112.5 lbf)	01/2362		
1000 N (225 lbf)	01/2419		
2500 N (562.50 lbf)	01/2363	Temperature Chambers and High Temperature Furnaces:	
5000 N (1124 lbf)	01/2364	A range of thermal chambers and furnaces are available. For further information see our specification sheets.	
10 kN (2248 lbf)	01/2365		
20 kN (4496 lbf)	01/2417		
30 kN (6744 lbf)	01/2366	Splinter Shields:	
50 kN (11241 lbf)	01/2367	Splinter shields can be supplied to your specific requirements. Contact Lloyd Instruments for further information.	
100 kN (22481 lbf)	01/2896		
Application Software:		LS100Plus-CC Large Compression Cage Option:	
NEXYGENPlus	40/0771	The LS100Plus machine can be ordered mounted above a floor standing compression cage for larger sample testing. Contact Lloyd Instruments to discuss your specification needs.	

Machine Dimensions

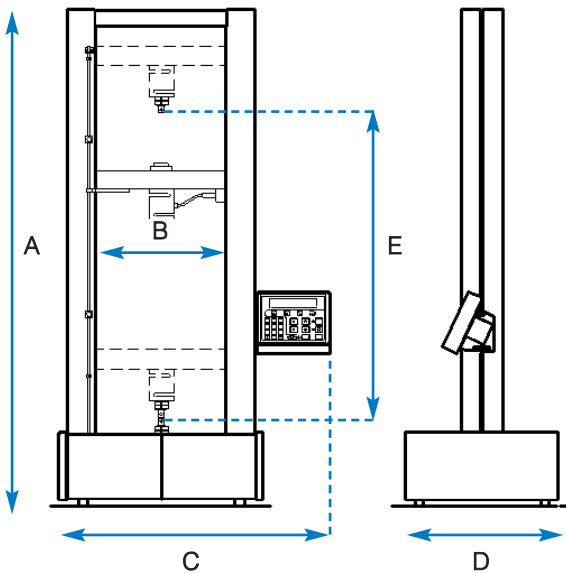

	mm	in
A (Standard machine height)	1567	61.7
A (Extended machine height)	1857	73.1
B	404	16.0
C	868	34.2
D	596	23.5
E (Standard machine travel)	824	32.4
E (Extended machine travel)	1012	39.8



Tensile test



Compression test



Flexure test

Ordering Information

Model	Part No	Capacity	Description
LS100Plus	01/3174	100 kN (22481 lbf)	LS100Plus Materials Testing Machine with Console
LS100Plus-E	01/3301	100 kN (22481 lbf)	LS100Plus Materials Testing Machine (Extended) with Console

AMETEK®
MEASUREMENT & CALIBRATION
TECHNOLOGIES

www.ametek.com

UK
Lloyd Instruments Ltd
12 Barnes Wallis Road
Segensworth East, Fareham
Hants, PO15 5TT

Tel +44 (0)1489 486 399
Fax +44 (0)1489 885 118
E-mail uk-far.general@ametek.co.uk
Web www.lloyd-instruments.co.uk

USA
AMETEK Measurement & Calibration
Technologies Division
8600 Somerset Drive
Largo, Florida 33773

Tel +1 (727) 536 7831
Fax +1 (727) 539 6882
E-mail chatillon.fl-lar@ametek.com
Web www.lloyd-instruments.com
www.chatillon.com

Far East
AMETEK Singapore Pte Ltd
10 Ang Mo Kio Street 65
#05-12 Techpoint
SINGAPORE 569059

Tel +65 6484 2388
Fax +65 6481 6588
E-mail aspl@ametek.com.sg
Web www.lloyd-instruments.com

France
AMETEK S.A.S.
Rond Point de l'Épine des Champs
Buro Plus - Bât. D
78990 Elancourt

Tel +33 (0)1 30 68 89 40
Fax +33 (0)1 30 68 89 49
E-mail general@lloyd-instruments@
ametek.fr
Web www.lloyd-instruments.fr

Germany
AMETEK GmbH
Rudolf-Diesel-Straße 16
D-40670 Meerbusch

Tel +49 (0)2159 9136-0
Fax +49 (0)2159 9136-39
E-mail info@ametek.de
Web www.ametek.de



0251

CERTIFICATE No 02511111