

## LRXPlus 5 kN Universal Materials Testing Machine

The LRXPlus universal testing system is ideal for materials testing applications up to 5 kN (1124 lbf). Suitable for both routine and complex test applications, the standard LRXPlus features a single column design with a crosshead travel range of 735 mm (29 in). Extended machine column options (LRXPlus-E models) for testing high elongation materials are also available.

This bench mounted machine is microprocessor controlled and incorporates world proven 32 bit technology for highly accurate load measurement and rapid data acquisition.

The LRXPlus features an integral control console with large, positive action membrane keys, allowing complex tests to be performed at the touch of a button. A back lit 4 line LCD display shows the test and set-up information in a wide choice of user selectable languages and units.

The stand alone system is capable of storing up to 600 test results from a choice of ten programmable test set-ups. Test parameters are entered using the keypad in a sequential menu driven format.

For additional flexibility, the LRXPlus can also be connected to a personal computer with optional Lloyd Instruments NEXYGENPlus material test and control software. NEXYGEN software provides almost unlimited testing and results processing capability in a familiar Windows® environment.

A series of highly accurate, interchangeable load cells is available for tension, compression and cycling through zero force measurements. Our extensive range of grips and fixtures support virtually any type of test. The system is ideal for use in production, quality control, educational and research environments.

### Features

- Simple to set up, operate and maintain
- High accuracy load measurement
- Constant load holding
- Data sampling rate 8 kHz
- Load rate control
- Saves up to 600 test results
- 10 programmable test set ups
- Pre-loading of samples and cycling to load or extension limits
- Multi-stage testing with NEXYGENPlus software
- Extension resolution < 0.1 microns
- Multi-lingual display options
- Multi-unit display options
- Flash upgradeable
- Extended column options for testing high extension materials
- Wide selection of load cells, grips, jigs, extensometers, temperature chambers and other accessories

### Specifications

Force Capacity:	
<b>LRXPlus (Standard)</b>	5 kN (1124 lbf)
<b>LRXPlus-E (Extended)</b>	2.5 kN (562 lbf)
Crosshead Speed Range:	0.01 to 1016 mm/min (0.0004 to 40 in/min)
Speed Accuracy:	<0.2% at steady state
Maximum Crosshead Travel:	
<b>LRXPlus</b>	735 mm (29 in)
<b>LRXPlus-E</b>	1370 mm (54 in)
Throat Depth:	135 mm (5.3 in)
Minimum Load Resolution:	0.0001 N (load cell specific)
Load Cell Accuracy:	<0.5%
Extension Resolution:	<0.1 microns
Data Sampling Rate:	8 kHz
Display:	40 character x 4 line backlit LCD
Extensometer Inputs:	Digital and Analogue
Load Measuring System:	EN ISO 7500:2004 Class 0.5 ASTM E4
Software:	NEXYGENPlus Data Analysis Software (optional)
Supply Voltage:	230Vac ±10%, 50-60 Hz, Fuse T3.15AH250V 115Vac ±10%, 50-60 Hz, Fuse T6.3AH250V
Weight:	
<b>LRXPlus</b>	50 kg (110 lb)
<b>LRXPlus-E</b>	52 kg (115 lb)
Operating Temperature:	5° to 35°C (41° to 95°F)



## Accessories

Item	Part No	Item	Part No
<b>XLC Series Load Cells:</b>		<b>Extensometers:</b>	
5 N (1.12 lbf)	01/2946	A comprehensive range of contacting and non-contacting extensometers are available. For further information see our extensometer specification sheets.	
10 N (2.25 lbf)	01/2360		
20 N (4.5 lbf)	01/2950		
50 N (11.25 lbf)	01/2361	<b>Splinter Shields</b>	
100 N (22.5 lbf)	01/2480	Splinter shield without electrical interlock	07/2058/F
250 N (56.25 lbf)	01/3048	(lower shield suitable for fixtures/samples up to 125 mm (4.92 in) in diameter)	
500 N (112.5 lbf)	01/2362		
1000 N (225 lbf)	01/2419	Splinter shield with electrical interlock	01/3064
2500 N (562.50 lbf)	01/2363	(lower shield suitable for fixtures/samples up to 125 mm (4.92 in) in diameter)	
5000 N (1124 lbf)	01/2364		
<b>Application Software:</b>		Larger shields are available on request	
NEXYGEN <i>Plus</i>	40/0771	<b>LRX<i>Plus</i>-CC Large Compression Cage Option</b>	
<b>Grips &amp; Fixtures:</b>		The LRX <i>Plus</i> machine can be ordered mounted above a floor standing compression cage for larger sample testing. Contact Lloyd Instruments to discuss your specification needs.	
A wide range of grips and fixtures are available. For further information see our grip specification sheets.			

## Machine Dimensions

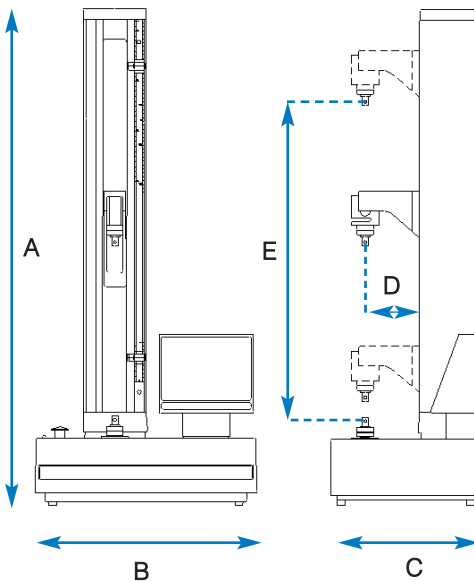

	mm	in
A (Standard machine height)	1260	49.6
A (Extended machine height)	1995	78.5
B	564	22.2
C	400	15.7
D	135	5.3
E (Standard machine travel)	735	29.0
E (Extended machine travel)	1370	54.0



Tensile test



Compression test



Flexure test

## Ordering Information

Model	Part No	Capacity	Description
LRX <i>Plus</i>	01/2962	5 kN (1124 lbf)	LRX <i>Plus</i> Materials Testing Machine with Console
LRX <i>Plus</i> -E	01/2990	2.5 kN (562 lbf)	LRX <i>Plus</i> Materials Testing Machine (Extended) with Console

**AMETEK**  
MEASUREMENT & CALIBRATION  
TECHNOLOGIES

www.ametek.com

**UK**  
Lloyd Instruments Ltd  
12 Barnes Wallis Road  
Segensworth East, Fareham  
Hants, PO15 5TT

Tel +44 (0)1489 486 399  
Fax +44 (0)1489 885 118  
E-mail uk-far.general@ametek.co.uk  
Web www.lloyd-instruments.co.uk

**USA**  
AMETEK Measurement & Calibration  
Technologies Division  
8600 Somerset Drive  
Largo, Florida 33773

Tel +1 (727) 536 7831  
Fax +1 (727) 539 6882  
E-mail chatillon.fl-lar@ametek.com  
Web www.lloyd-instruments.com  
www.chatillon.com

**Far East**  
AMETEK Singapore Pte Ltd  
10 Ang Mo Kio Street 65  
#05-12 Techpoint  
SINGAPORE 569059

Tel +65 6484 2388  
Fax +65 6481 6588  
E-mail aspl@ametek.com.sg  
Web www.lloyd-instruments.com

**France**  
AMETEK S.A.S.  
Rond Point de l'Épine des Champs  
Buro Plus - Bât. D  
78990 Elancourt

Tel +33 (0)1 30 68 89 40  
Fax +33 (0)1 30 68 89 49  
E-mail general@lloyd-instruments@  
ametek.fr  
Web www.lloyd-instruments.fr

**Germany**  
AMETEK GmbH  
Rudolf-Diesel-Straße 16  
D-40670 Meerbusch

Tel +49 (0)2159 9136-0  
Fax +49 (0)2159 9136-39  
E-mail info@ametek.de  
Web www.ametek.de



0251

CERTIFICATE No: 0251/11/11