

EZ Series EZ20 20 kN Universal Materials Testing Machine

The EZ20 advanced materials testing machine incorporates an extensive range of features making it ideal for performing complex as well as routine testing applications up to 20 kN (4496 lbf). The EZ20 features a twin column design with a standard crosshead travel of 870 mm (34.3 in).

This bench mounted machine is microprocessor controlled and incorporates world proven 32 bit technology for highly accurate load measurement and rapid data acquisition. The EZ20 features an integral user interface consisting of a side mounted control console with large, positive action membrane keys, allowing complex tests to be performed at the touch of a button. A back lit 4 line LCD display shows the test and set up information in a wide choice of user selectable languages and units.

The stand alone system is capable of storing up to 600 test results from a choice of ten programmable test set ups. Test parameters are entered using the keypad in a sequential menu driven format.

For additional flexibility, the EZ20 can also be connected to a personal computer with optional Lloyd Instruments NEXYGEN*Plus* material test and control software. NEXYGEN*Plus* software provides almost unlimited testing and results processing capability in a familiar Windows® environment.

The high stiffness frame incorporates a crosshead guidance system to prevent side loading of the sample under test. The crosshead is driven by twin lead screws and a high precision servo motor and DC servo system to achieve a wide range of speeds.

A series of highly accurate, interchangeable load cells is available for tension, compression and cycling through zero force measurements. Our extensive range of grips and fixtures support virtually any type of test. The system is ideal for non-continuous testing use in production, quality control, education and research environments. Where continuous testing is required, we recommend the Lloyd Instruments LR30K*Plus* 30 kN materials testing machine.

Features

- Simple to set up, operate and maintain
- High accuracy load measurement
- Constant load holding
- Data sampling rate 8 kHz
- Load rate control
- Saves up to 600 test results
- 10 programmable test set ups
- Pre-loading of samples and cycling to load or extension limits
- Multi-stage testing with NEXYGEN*Plus* software
- Extension resolution < 0.1 microns
- Multi-lingual display options
- Multi-unit display options
- Flash upgradeable
- Extended column options for testing high extension materials
- Wide selection of load cells, grips, jigs, extensometers, temperature chambers and other accessories

Specifications

Force Capacity:	
EZ20 (Standard)	20 kN (4496 lbf)
EZ20-E (Extended)	20 kN (4496 lbf)
Crosshead Speed Range:	0.001 to 508 mm/min up to 20 kN (0.00004 to 20 in/min up to 4496 lbf)
	0.01 to 1016 mm/min up to 10 kN (0.0004 to 40 in/min up to 2248 lbf)
Speed Accuracy:	< 0.2% at steady state
Travel:	
EZ20	870 mm (34.3 in)
EZ20-E	1370 mm (54 in)
Width Between Columns:	404 mm (16 in)
Minimum Load Resolution:	0.0001N (Load cell specific)
Load Cell Accuracy:	<0.5%
Extension Resolution:	< 0.1 microns
Data Sampling Rate:	8 kHz
Display:	40 character x 4 line backlit LCD
Extensometer Inputs:	Digital and Analogue
Load Measuring System:	EN ISO 7500:2004 Class 0.5 ASTM E4
Software:	NEXYGEN <i>Plus</i> Data Analysis Software (optional)
Supply Voltage:	230Vac ±10%, 50-60 Hz, Fuse T5AH250V, 115Vac ±10%, 50-60 Hz, Fuse T10AH250V
Weight:	
EZ20	148 kg (326 lb)
EZ20-E	152 kg (335 lb)
Operating Temperature:	5° to 35° C (41° to 95° F)



Accessories

Item	Part No	Item
XLC Series Load Cells:		Extensometers:
5 N (1.12 lbf)	01/2946	We supply contacting and non-contacting extensometers. For further information see our extensometer specification sheets.
10 N (2.25 lbf)	01/2360	
20 N (4.5 lbf)	01/2950	
50 N (11.25 lbf)	01/2361	
100 N (22.5 lbf)	01/2480	
250 N (56.25 lbf)	01/3048	Temperature Chambers and High Temperature Furnaces:
500 N (112.5 lbf)	01/2362	A range of thermal chambers and furnaces are available. For further information see our specification sheets.
1000 N (225 lbf)	01/2419	
2500 N (562.50 lbf)	01/2363	
5000 N (1124 lbf)	01/2364	
10 kN (2248 lbf)	01/2365	Splinter Shields:
20 kN (4496 lbf)	01/2417	Splinter shields can be supplied to your specific requirements. Contact Lloyd Instruments for further information.
Application Software:		EZ20 Large Compression Cage Option:
NEXYGENPlus	40/0771	The EZ20 machine can be ordered mounted above a floor standing compression cage for larger sample testing. Contact Lloyd Instruments to discuss your specification needs.
Grips & Fixtures:		
A wide range of grips and fixtures are available. For further information see our grip specification sheets.		

Machine Dimensions

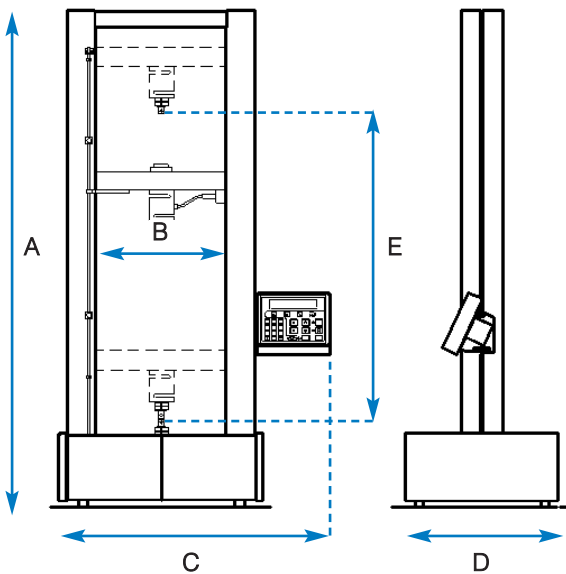

	mm	in
A (Standard machine height)	1567	61.7
A (Extended machine height)	2067	81.4
B	404	16.0
C	868	34.2
D	596	23.5
E (Standard machine travel)	870	34.3
E (Extended machine travel)	1370	54.0



Tensile test



Compression test



Flexure test

Ordering Information

Model	Part No	Capacity	Description
EZ20	01/2889	20 kN (4496 lbf)	EZ20 Materials Testing Machine with Console
EZ20-E	01/3375	20 kN (4496 lbf)	EZ20 Materials Testing Machine (Extended) with Console

AMETEK®
MEASUREMENT & CALIBRATION
TECHNOLOGIES

www.ametek.com

UK
Lloyd Instruments Ltd
12 Barnes Wallis Road
Segensworth East, Fareham
Hants, PO15 5TT

Tel +44 (0)1489 486 399
Fax +44 (0)1489 885 118
E-mail uk-far.general@ametek.co.uk
Web www.lloyd-instruments.co.uk

USA
AMETEK Measurement & Calibration
Technologies Division
8600 Somerset Drive
Largo, Florida 33773

Tel +1 (727) 536 7831
Fax +1 (727) 539 6882
E-mail chatillon.fl-lar@ametek.com
Web www.lloyd-instruments.com
www.chatillon.com

Far East
AMETEK Singapore Pte Ltd
10 Ang Mo Kio Street 65
#05-12 Techpoint
SINGAPORE 569059

Tel +65 6484 2388
Fax +65 6481 6588
E-mail aspl@ametek.com.sg
Web www.lloyd-instruments.com

France
AMETEK S.A.S.
Rond Point de l'Épine des Champs
Buro Plus - Bât. D
78990 Elancourt

Tel +33 (0)1 30 68 89 40
Fax +33 (0)1 30 68 89 49
E-mail general@lloyd-instruments@
ametek.fr
Web www.lloyd-instruments.fr

Germany
AMETEK GmbH
Rudolf-Diesel-Straße 16
D-40670 Meerbusch

Tel +49 (0)2159 9136-0
Fax +49 (0)2159 9136-39
E-mail info@ametek.de
Web www.ametek.de



0251

CERTIFICATE No: 0259111111